

CL-PCDH-1M Series Pressurized Step-down Crystal Driver

PARAMETERS

Specifications	
Series	CL-PCDH-1M series
Model	CL-PCDH-1M-2.9
High voltage maximum rated voltage	2.9 kV
High voltage maximum working voltage	2.7 kV
High voltage maximum repetition rate	1000 kHz
Pulse duration	100 – 5000 ns
High voltage pulse rise time	<7 ns
High voltage pulse fall time	<7 ns
External trigger signal amplitude	3.5–5 V (50 Ω load)
External signal input interface	SMA
Indicator light	Power indication
Cooling method	Water cooling
Volume	135*68*45 mm (L*W*H)
High voltage power	OEM-HV-120
Power supply	DC24V

SIZE DIAGRAM (mm)

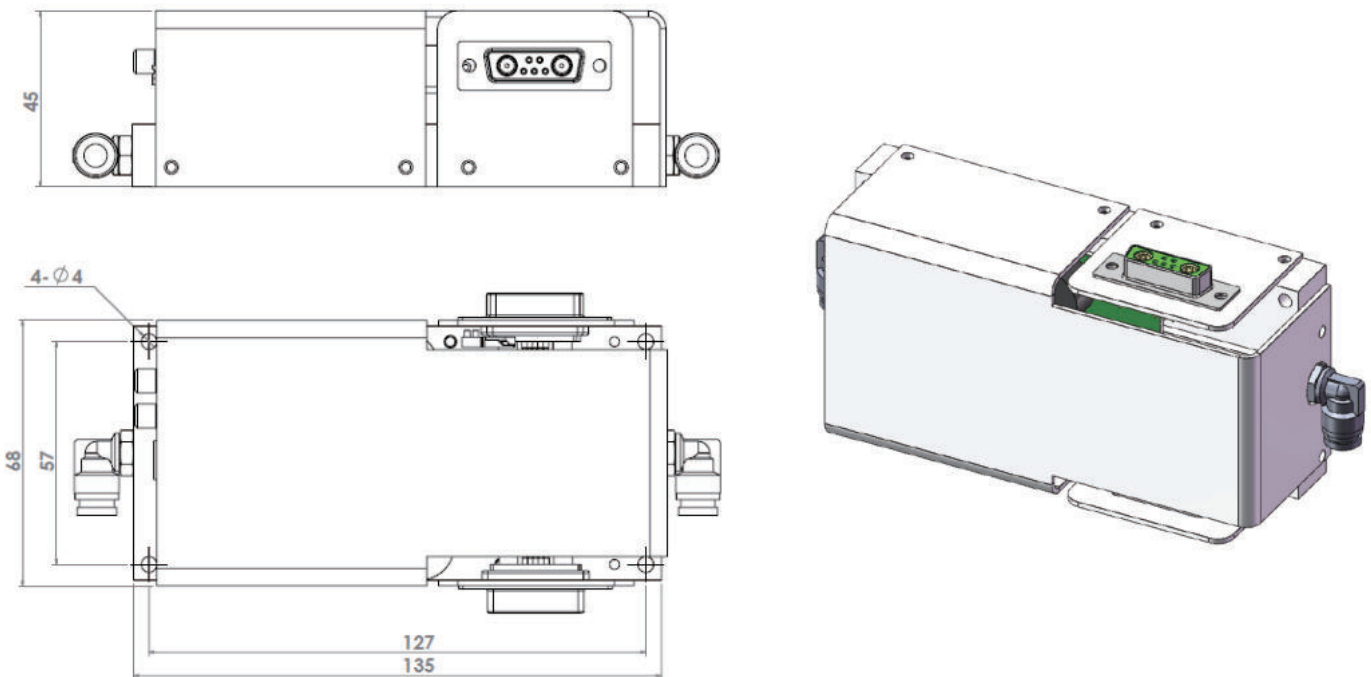

CL-PCDH-1M Series Pressurized Step-down Crystal Driver

SIGNAL CONTROL DIAGRAM

